

Series 75 Planetary DiggerDrive Service & Repair Manual

EFFECTIVE FOR:
FROM S/N: 23280
TO: (CURRENT)

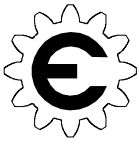

MODEL 75 SERVICE MANUAL

HYDRASYNC™ PLANETARY DIGGERDRIVE

This manual will assist in disassembly and assembly of major components for all Model 75 Hydrasync, Planetary Auger Drives. Item numbers, indicated in parentheses throughout this manual, refer to the Eskridge Model 75 exploded parts breakdown drawings. Individual customer specifications (output shaft hex size, motor, bail assembly, etc.) may vary from exploded drawing and standard part numbers shown. If applicable, refer to individual customer drawing for details.

LUBRICATION AND MAINTENANCE

The oil should be changed after the first 50 hrs. of use and at 500 hr. intervals thereafter. All gearboxes require GL-5 grade EP 80/90 gear oil for lubrication. The manufacturer recommends that the unit be partially disassembled to inspect gears and bearings at 1000 hour intervals.

OIL CAPACITY:

10.00 pints

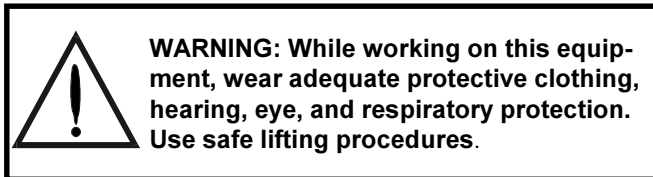

UNIT DISASSEMBLY PROCEDURE

(Refer to exploded view drawing on page 7)

- 1) Scribe a diagonal line across the outside of the unit from the cover (4) to the base (1) before disassembly to assure proper positioning of pieces during reassembly.
- 2) Remove magnetic drain plug (33) and drain oil from unit. Maximum drainage occurs when oil is warm.
- 3) Remove the twenty hex head capscrews (29) and lockwashers (32).
- 4) Remove bail (37), and motor (46)
- 5) Remove the cover (4), thrust washer (28), input gear (11), and carrier thrust washer (14). Inspect o-ring (15); discard if damaged or if it has taken a set.

6) Lift the primary planet carrier assembly out of the unit (includes items 5, 10, 13, 16, 25, & 30).

7) If sun gear (9) has not been removed from gearbox, do so now. (Sometimes the sun gear remains in the primary carrier (5).)

8) Remove primary ring gear (2). Inspect second o-ring (15), as before; discard if damaged.

9) Remove carrier thrust washer (14). Lift the secondary planetary assembly out of the unit (includes items 6, 8, 12, 17, 23, 24, & 31). Use a puller if necessary.

10) Remove secondary ring gear (3). Inspect third o-ring (15), as before; discard if damaged.

11) The unit is now disassembled into groups of parts. The area(s) requiring repair should be identified by thorough inspection of the parts after they have been cleaned and dried. Then refer to the appropriate group repair section below.

1. Primary Planet Carrier subassembly
2. Secondary Planet Carrier subassembly
3. Base subassembly

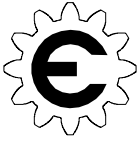

PRIMARY PLANET CARRIER SUBASSEMBLY

(ITEMS 5, 10, 13, 16, 25, & 30)
DISASSEMBLY AND REPAIR

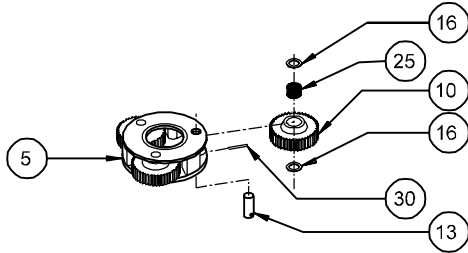

Rotate planet gears (10) to check for abnormal noise or roughness in bearings (25) or planet shafts (13). If further inspection or replacement is required, proceed as follows.

NOTE: Support carrier (5) only while pressing out planet shafts.

- 1) Drive roll pins (30) completely into the planet shafts (13).
- 2) Press or drive planet shafts (13) out of carrier (5).
- 3) Remove planet gears (10) and planet washers (16) from the carrier (5).
- 4) If the planet bearings (25) require replacement, press them out of the planet gears (10) and replace with new ones.
- 5) Check primary planet shafts (13) for any abnormal wear, especially ones where bearings needed to be replaced. If any abnormal wear is found, replace planet shafts.
- 6) Use 3/16 inch pin punch to remove roll pins (30) from planet shafts (13).

RE-ASSEMBLY

- 7) With planet washers (16) on both sides of the planet gear (10) and with bearings (25) installed, slide gear into the carrier (5). Insert the planet shaft (13) through the carrier, washers, and planet gear.
- 8) Planet shafts (13) should be installed with chamfered end of 3/16 inch hole toward outside diameter of the carrier (5). This will aid in alignment of holes while inserting roll pins (30).
- 9) Drive a roll pin (30) through the carrier hole and into the planet shaft to retain the parts. Repeat for other planet gears.

SECONDARY PLANET CARRIER SUBASSEMBLY

(ITEMS 6, 8, 12, 17, 23, 24, & 31)
DISASSEMBLY AND REPAIR

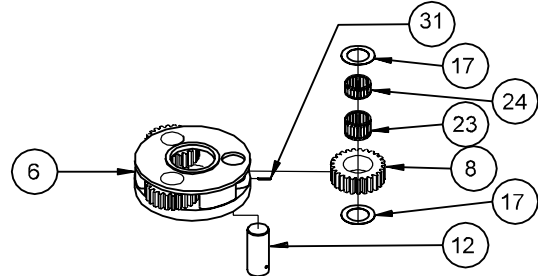

Follow the same procedure as that for the primary planetary assembly. Substitute items as indicated: planet gears (8), planet bearings (23 & 24), planet shafts (12), roll pins (31), carrier (6) and washers (17).

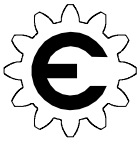

BASE SUBASSEMBLY

(ITEMS 1, 7, 18, 19, 20, 21, 22, 26, 27, 33, & 35)

DISASSEMBLY AND REPAIR

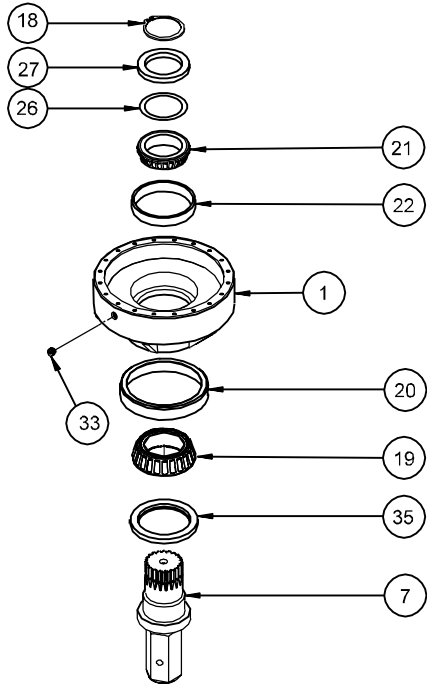

1) Remove the shaft retaining ring (18). Remove the spacer (27) and shim(s) (26).

CAUTION: Output shaft is no longer retained. Care should be taken not to injure feet because output shaft can fall out. Care should also be taken not to damage output shaft when shaft is pressed through base.

2) Output shaft removal. Base (1) should be set pinion side down, as shown, on a plate or table with output shaft (7) protruding through a hole in table. Press output shaft out bottom of base by applying a load to top end (internal end) of shaft until it passes through inner shaft bearing cone (21).

3) If outer bearing cone (19) (on the shaft) needs to be removed a gear puller may be used, otherwise skip to step number 6. If reusing old bearing cone, do not pull on or damage roller cage. Remove the shaft seal (35) for inspection or replacement.

4) Lubricate inner lip of new shaft seal (35) and slide the seal onto the shaft (7) until it fits snugly over shaft seal diameter with the open side toward the inside of the gearbox.

NOTE: Press bearing cone onto output shaft by pressing on inner race only. DO NOT press on roller cage or it may damage bearing.

5) Press outer bearing cone (19) (large end down as shown) onto the shaft until it seats against the shoulder. Bearing cone (19) may be reused if it was removed only to replace the seal (35).

6) Inspect inner and outer bearing cups (20 & 22) and replace if necessary.

BASE ASSEMBLY

1) Clean all foreign material from magnetic oil plug (33) located on side of base (1). Add a small amount of pipe thread compound to pipe plug before installing back into base.

2) Place the base (1) (output side up, opposite shown) on the press table.

3) Apply a layer of lithium or general purpose bearing grease to surface of outer bearing cup (20). Insert the shaft into the base (bearing cone down) and use a soft hammer to install the shaft seal (35) into the mounting base.

CAUTION: Output shaft is not retained at this point.

4) Invert this assembly so it is standing on the shaft (on the press table).

NOTE: Press bearing cone onto output shaft by pressing on inner race only. DO NOT press on roller cage or it may damage bearing.

5) Apply a layer of lithium or general purpose bearing grease to surface of inner bearing cup (22). Press the inner bearing cone (21) (large end up as shown) onto the shaft (7) until it is just seated against inner bearing cup (22). A slight preload of less than 100 in-lbs rolling torque should be obtained.

6) Relieve the press and slide the shim(s) (26) and the spacer (27) onto the shaft (7). Install the retaining ring (18) into the shaft groove. It is important that the retaining ring is completely seated in the groove. If the retaining ring cannot be installed into the groove, one shim must be removed and the procedure must be repeated. Once the retaining ring is installed, check for proper shaft bearing preload by pressing down on the end of the shaft and rotating the mounting base. There should be from 20 to 60 in-lbs of rolling resistance in the bearings. If the retaining ring is not tight against the spacer, remove the spacer and add one shim and repeat the procedure until the preload is acceptable.

All subassembly service or repairs should be complete at this time. Continue on through UNIT ASSEMBLY to complete unit buildup.

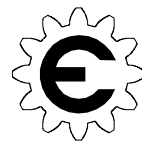

UNIT ASSEMBLY REASSEMBLING

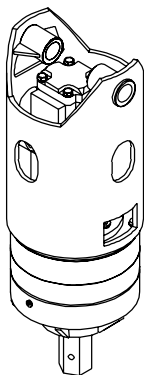

(Refer to exploded drawing on page 7)

13) Fill to proper level, as specified on page 2, with EP 80/90 gear oil.

THE DIGGERDRIVE IS NOW READY TO USE.

1) When all subassemblies are complete, unit is ready to be assembled.

2) Lubricate o-ring (15) and install on the O.D. pilot of the secondary ring gear (3). Referring to scribe marks for proper orientation, install the secondary ring gear (3) onto the base (1).

3) Install the secondary planet carrier (6); assemble by rotating it until planet gears line up with ring gear teeth and shaft spline. Press until fully seated on shaft (7).

4) Lubricate o-ring (15) and install on the O.D. pilot of the primary ring gear (2) and install the primary ring gear (2). Refer to scribe marks for proper orientation.

5) Slide the sun gear (9) into the secondary planet carrier (6).

6) Install carrier thrust washer (14).

7) Install primary planet carrier (5); assemble by rotating it until planet gears line up with ring gear teeth and sun gear spline. Assembly should drop into place.

8) Slide the input gear (11) into the primary planetary carrier.

9) Install carrier thrust washer (14) and input gear thrust washer (28).

10) Lubricate o-ring (15) and install on the O.D. pilot of the cover (4). Position the cover (4) with the proper orientation.

11) Install the motor (46) using new o-ring (45), if necessary.

12) Install bail and be sure it is oriented correctly with the cover. Install the twenty 1/2-13 capscrews (29) with hardened, flatwashers (32) and torque to 110 ft-lbs(dry), 80 ft-lbs(lubed).

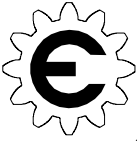

PRODUCT WARRANTY

ESKRIDGE, INC. ("Eskridge") warrants to its original purchaser ("Customer") that new component parts ("Parts") sold by Eskridge to the Customer will be free of defects in material and workmanship and will conform to standard specifications set forth in current Eskridge sales literature or to any custom specifications of the Customer acknowledged in writing by Eskridge, **SUBJECT TO THE FOLLOWING QUALIFICATIONS AND LIMITATIONS:**

- 1) Prior to placing warranted Parts in service, the Customer shall provide proper storage such that foreign objects (e.g., rain or debris) cannot enter any Parts via entry ports which are normally closed during operation.
- 2) If Parts requiring motorized power for operation are received from Eskridge without a motor, documentation must be available indicating proper lubrication upon placement of the Parts in service.
- 3) The Customer must notify Eskridge in writing of any claim for breach of this warranty promptly after discovery of a defect and in any event prior to the termination of the warranty period, which shall commence when a unit is placed in service and shall expire upon the earlier of (i) the expiration of twelve (12) months from the date of Commencement of Service (as defined in Paragraph 4) (ii) the completion of one thousand (1,000) hours of service of the Parts (iii) the expiration of six (6) months after the expiration of any express warranty relating to the first item of machinery or equipment in which the Parts are installed or on which it is mounted, or (iv) the installation or mounting of the Parts in or on an item of machinery or equipment other than the first such item in which the Parts are installed or on which the Parts are mounted.
- 4) Parts shall be deemed to have been placed in service (the "Commencement of Service") at the time the machinery or equipment manufactured or assembled by the Customer and in which the Parts are installed or on which the Parts are mounted is delivered to the Customer's dealer or the original end-user, whichever ever receives such machinery or equipment first.
- 5) This warranty shall not apply with respect to Parts which, upon inspection by Eskridge, show signs of disassembly, rework, modifications or improper installation, mounting, use or maintenance.
- 6) Eskridge makes no warranty in respect to hydraulic motors mounted on any Parts. Failure of any such motor will be referred to the motor manufacturer.
- 7) Claims under this warranty will be satisfied only by repair of any defect(s) or, if repair is determined by Eskridge in its sole, absolute and uncontrolled discretion to be impossible or impractical, by replacement of the Parts or any defective component thereof. No cash payment or credit will be made for defective materials or workmanship. **IN NO EVENT SHALL ESKRIDGE BE LIABLE FOR INCIDENTAL OR CONSEQUENTIAL DAMAGES OF ANY KIND OR NATURE, WHICH DAMAGES ARE HEREBY EXPRESSLY DISCLAIMED.**
- 8) From time to time, Eskridge may make changes in the component parts manufactured by it without incorporating such changes in the component parts previously shipped. Such changes shall not constitute an admission by Eskridge of any defects or problems with previously manufactured component parts.
- 9) All freight charges on Parts returned for warranty service are the responsibility of the Customer.

THE FOREGOING WARRANTY IS THE SOLE WARRANTY MADE BY ESKRIDGE WITH RESPECT TO ANY PARTS, AND IS IN LIEU OF ANY AND ALL OTHER WARRANTIES, EXPRESSED OR IMPLIED. THERE ARE NO WARRANTIES WHICH EXTEND BEYOND THE DESCRIPTION ON THE FACE HEREOF. WITHOUT LIMITING THE GENERALITY OF THE FOREGOING, ESKRIDGE EXPRESSLY DISCLAIMS ANY IMPLIED WARRANTY OF MERCHANTABILITY OR FITNESS FOR ANY PARTICULAR PURPOSE, REGARDLESS OF ANY KNOWLEDGE ESKRIDGE MAY HAVE OF ANY PARTICULAR USE OR APPLICATION INTENDED BY THE PURCHASER. THE SUITABILITY OR FITNESS OF THE PARTS FOR THE CUSTOMER'S INTENDED USE, APPLICATION OR PURPOSE AND THE PROPER METHOD OF INSTALLATION OR MOUNTING MUST BE DETERMINED BY THE CUSTOMER.

WARRANTY RETURN POLICY

- 1) All Parts shall be returned freight prepaid.
- 2) Any Parts qualifying for warranty will be repaired with new Parts free of charge (except for freight charges as provided above).
- 3) If parts are found to be operable, you have two options:
 - a. The Parts can be returned to you with a service charge for inspection, cleaning, and routine replacement of all rubber components and any other parts that show wear; or
 - b. We can dispose of the Parts at the factory if you do not wish it to be returned.

NOTE: Any order of Parts by customer shall only be accepted by Eskridge subject to the terms stated herein. Any purchase order forms used by Customer (to accept this offer to sell) which contain terms contrary to, different from, or in addition to the terms herein shall be without effect, and such terms shall constitute material alteration of the offer contained herein under K.S.A 84-2-207 (2)(b), and shall not become part of the contract regarding the sale of the Parts.

MODEL 75 SERIES HYDRASYNC AUGER DRIVE



EFFECTIVE FOR:
FROM: S/N 23280 02-17-98
TO: (CURRENT)

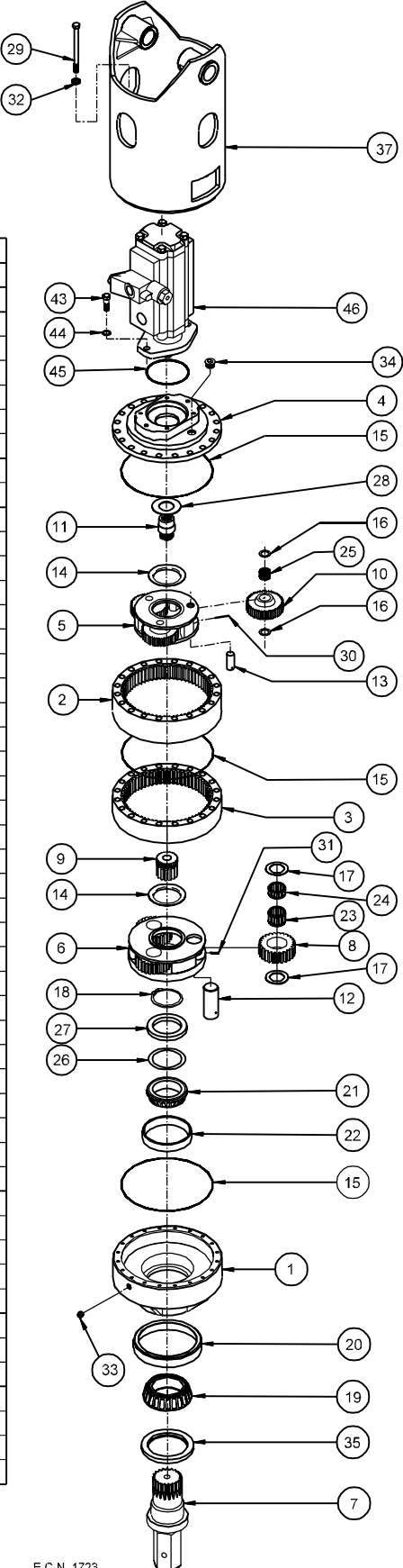

		RATIO PRI.:1/SEC.:1	51.43:1	40.25:1	37.80:1	29.58:1
ITEM	QTY	DESCRIPTION	PART NO.	PART NO.	PART NO.	PART NO.
			8.5714/6.00	8.5714/4.6957	6.3000/6.00	6.3000/4.6957
1	1	BEARING CARRIER 75	75-004-3012			
2	1	RING GEAR-PRIMARY	25-004-1012			
3	1	RING GEAR-SECONDARY	25-004-1022			
4	1	COVER	25-004-1222			
5	1	CARRIER-PRIMARY	25-004-1032	25-004-1032	25-004-1042	25-004-1042
6	1	CARRIER-SECONDARY	25-004-1062	25-004-1072	25-004-1062	25-004-1072
7	1	OUTPUT SHAFT 2 5/8 HEX (75/250)	75-004-4022			
		OUTPUT SHAFT 3" HEX (75/250)	75-004-4012			
8	3	PLANET GEAR-SECONDARY	25-004-1082	25-004-1092	25-004-1082	25-004-1092
9	1	SUN GEAR-SECONDARY	25-004-1142	25-004-1152	25-004-1142	25-004-1152
10	3	PLANET GEAR-PRIMARY	25-004-1102	25-004-1102	25-004-1112	25-004-1112
11	1	INPUT GEAR 14 T 12/24 SPLINE	25-004-1162	25-004-1162	25-004-1172	25-004-1172
12	3	PLANET SHAFT-SECONDARY	25-004-1021			
13	3	PLANET SHAFT-PRIMARY	25-004-1031			
14	2	THRUST WASHER-SECONDARY (CAR.)	25-004-1132			
15	3	O-RINGS- 276	01-402-0020			
16	6	WASHER-PRIMARY PLANET	81-004-1561			
17	6	WASHER-SECONDARY PLANET	25-004-1041			
18	1	RETAINING RING-	01-160-0600			
19	1	BEARING CONE-	01-102-0120			
20	1	BEARING CUP-	01-103-0110			
21	1	BEARING CONE-	01-102-0250			
22	1	BEARING CUP-	01-103-0250			
23	3	BEARING-SEC.	01-105-0550			
24	3	BEARING-SEC.	01-105-0560			
25	3	BEARING-PRI.	01-105-0570			
26	*	SHIM (0.005") steel	25-004-1051			
27	1	SUPPORT RING	25-004-1061			
28	1	THRUST WASHER	81-004-2883			
29	20	HHCS-(1/2-13x7.5) GR8	01-150-1660			
30	3	SPRING PIN-(3/16x1)	01-153-0020			
31	3	SPRING PIN-(3/16x1 1/4)	01-153-0190			
32	20	FLAT WASHER-(1/2 X 7/8 X 1/8)	01-166-0120			
33	1	PIPE PLUG-(1/2 NPT MAGNETIC)	01-207-0041			
34	1	PLUG-(PARKER# 05HP-12)	01-208-0030			
35	1	SEAL	01-405-0500			
BAILS	37	2" BOSS C.S. M76 MOTOR , BACKHOE	75-005-2132			
		2" BOSS- BACKHOE, M50 1.25 X 2.5 - 2.5 X 2.5 MTRS	75-005-2092			
		1.5" BOSS, M50 1.25 X 2.5 THRU 2.5 X 2.5 MTRS.	75-005-2082			
		2" BOSS, M50 1.25 X 2.5 THRU 2.5 X 2.5 MTRS	75-005-2042			
		2" BOSS, C.S. M76 MOTOR	75-005-2012			
43	2	H.H.C.S. (5/8-11 X 1-3/4)	01-150-0110			
44	2	LOCKWASHER (5/8)	01-166-0040			
45	1	O-RING (PARKER NO. 250)	01-402-0010			
MOTORS	46	MOTOR - C.S. M50 1.5 X 2.5 (HI)	01-304-0250			
		MOTOR - C.S. M76A 998 BEVL30-7	01-304-0340			
		MOTOR - C.S. M50 2.5 X 2.5 (HI)	01-304-0450			
		MOTOR - C.S. WM51B 2.5 X 2.5 (HI)	01-304-0530			

* QUANTITY OF SHIMS DETERMINED BY BEARING PRELOAD.

OPTIONS
SEAL KIT P/N 25-016-2021
INCLUDES 1 EA. OF ITEM 35 AND ITEM 45.
PLUS A QTY 3 OF ITEM 15

E.C.N. 1723
SERV/ X75-0014 REV. C DATE: 09-22-99

OTHER ESKRIDGE PRODUCTS

PLANETARY GEARBOXES

MODEL

20/28 SERIES
50 SERIES
60 SERIES
100 SERIES
130 SERIES
150 SERIES
250 SERIES
600 SERIES
1000 SERIES

TORQUE RATING

MAX. INTERMITTENT
20,000-28,000 IN-LBS
50,000 IN-LBS
60,000 IN-S
100,000 IN-BS
130,000 IN-BS
150,000 IN-BS
250,000 IN-BS
600,000 IN-BS
1,000,000 IN-LBS

MULTIPLE DISC BRAKES

90B SAE B
90BA SAE B ADJUSTABLE TORQUE
92B SAE B LOW PROFILE
93 FOR NICHOLS MOTORS
95C SAE C
95W WHEEL MOUNT
98D SAE D

OUTPUT TORQUE
TO 4,800 IN-BS
TO 4,800 IN-BS
TO 2,800 IN-BS
TO 6,100 IN-BS
TO 12,000 IN-LBS
TO 21,000 IN-LBS
TO 25,000 IN-LBS

PLANETARY DIGGERDRIVES

D50 MODELS 1600, 2000 & 2800
76 MODELS BA & BC, TWO SPEED
77 MODELS BA, BC & BD
78 MODELS 35 & 48, TWO SPEED
75 MODELS 38 & 51, TWO SPEED

TORQUE RATING
1,500-4,500 FT-LBS
8,000-12,500 FT-LBS
6,000-12,500 FT-LBS
9,000-12,500 FT-LBS
16,500-20,000 FT-LBS



1900 Kansas City Road
Olathe, Kansas 66061
phone (913) 782-1238
fax (913) 782-4206

WEBSITE: www.eskridgeinc.com
E-MAIL: sales@eskridgeinc.com

Your nearest Eskridge Distributor is:

